



Rain elements

EUROPEAN GUTTER SYSTEMS

A new standard in **rain management**



IN PARTNERSHIP WITH



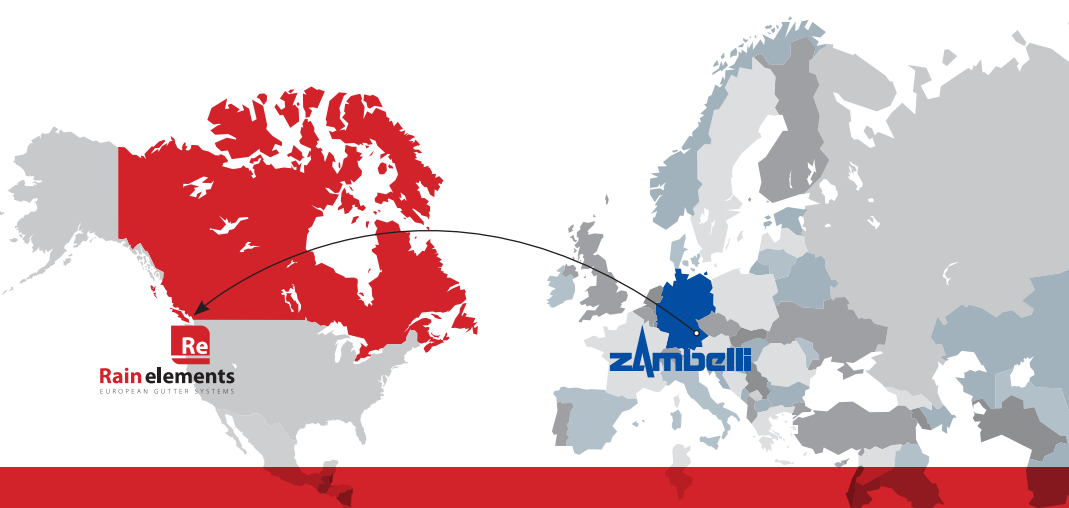

The ultimate roof drainage system...

Direct from Europe to a Canadian market

RainElements' European partner, The Zambelli Group, manufactures roof drainage systems in Europe using metalworking processes acquired from decades of experience. These advanced manufacturing techniques – applied to premium elements like copper, zinc and steel – result in a higher standard of product.

For years Canadian construction and design standards have been increasing. Now, Canada finally has easy access to an everlasting, stylish rain management system that compliments our progressive designs. Not only will RainElements systems last a lifetime, they will add value and distinction to any home or building.

Easy installation and maximum durability

Quick assembly is made possible by innovative product alternatives with plug-in and clamping connections – sparing you the need for time-consuming and complex riveting and soldering. Assembly is consistently simple because exact dimensional stability of diameter and degree value is guaranteed by patented manufacturing processes.

Once assembled, the high functionality of RainElements systems is owed not only to the quality of manufacturing but also to the ideal drainage rates provided.

Quick to assemble, easy to process and reliable in operation. Ultimately, a superior system to any other in quality, style and longevity.

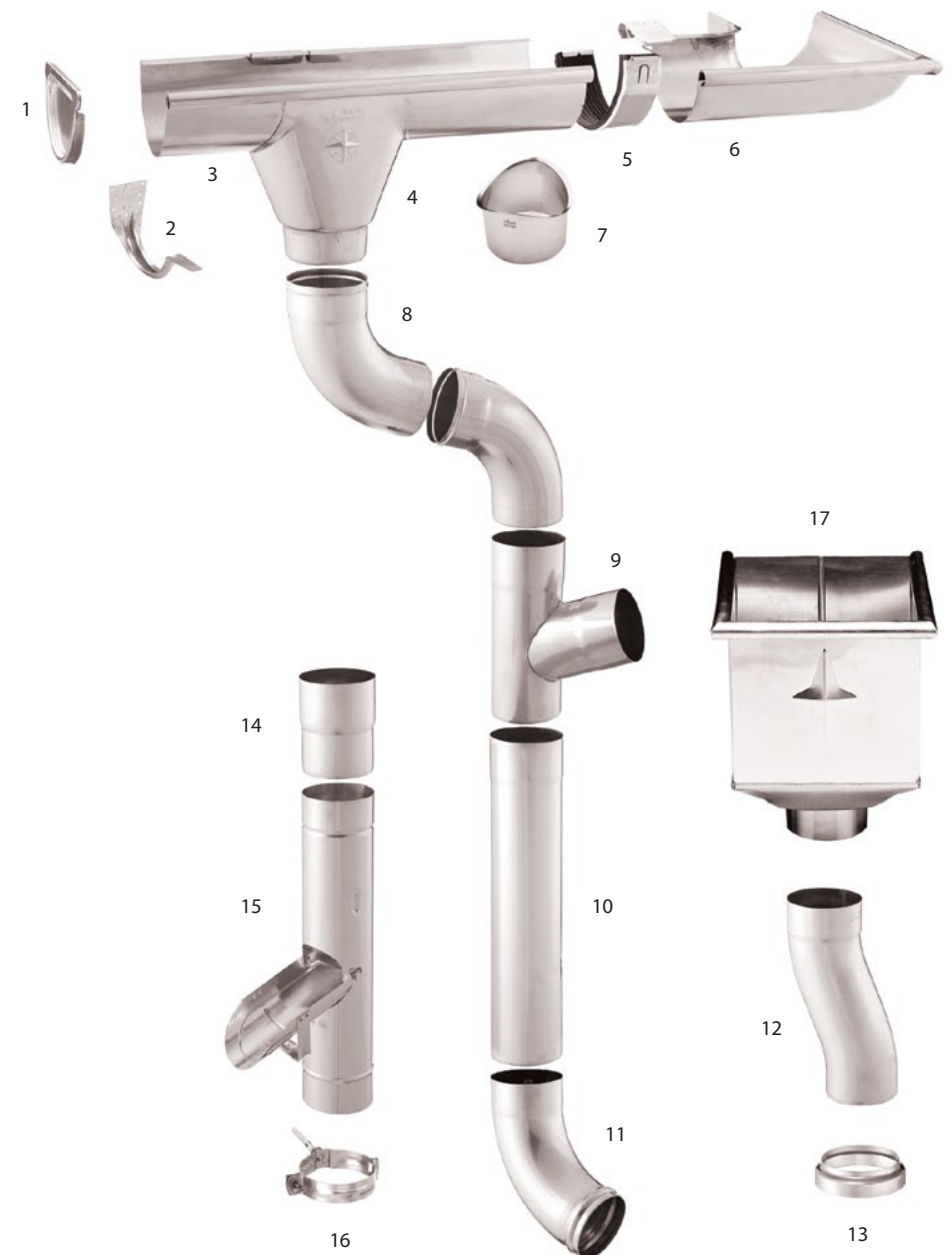

Product range:

- | | | |
|--------------------------------|---|---|
| 1. End Cap with rubber seal | 7. Mini outlet for soldering (Copper & Zinc only) | 12. S-Curve |
| 2. Gutter Bracket | 8. Elbow 72° | 13. Pipe Cover |
| 3. Gutter | 9. Downpipe Junction | 14. Downpipe Connector |
| 4. Outlet | 10. Downpipe | 15. Leaf Clean Out Pipe |
| 5. Gutter Connector | 11. Elbow 40° (Not available in Coated Steel) | 16. Bracket for Downpipe with thread socket |
| 6. Corners (inside or outside) | | 17. Collector Box |

elements of quality, distinction and elegance

Complete systems with precisely engineered components are available in each of the elements below.



Copper

A Rain Elements Copper Roof Drainage System is the ultimate rain management system available. Your pure copper roof drainage system will last a lifetime and add value and distinction to your home. Copper has low chemical reactivity and in moist air it slowly forms a patina coating. This coating protects the metal from further corrosive attacks and becomes more and more beautiful with age.



Cu

SPECIFICATIONS

LONGEVITY	GAUGE	TENSILE:	PURITY:	WARRANTY:
100 years	24	70	99.9%	15 years

Zinc

A RainElements Zinc Roof Drainage System is light-weight, amazingly durable and corrosion proof. Our zinc roof drainage system offers the best combination of quality, style and value available. Like copper, zinc has low chemical reactivity and in moist air it slowly forms a patina coating. This coating protects the metal from further corrosive attacks and becomes more and more beautiful with age.



Zn

SPECIFICATIONS

LONGEVITY	GAUGE	TENSILE:	PURITY:	WARRANTY:
100 years	24	41	99.9%	15 years

Galvanized Steel

A RainElements Steel Roof Drainage System combines maximum durability with a progressive, clean and modern look. Our steel roof drainage systems are made of a high strength, low weight, durable alloy which provides a quality, durability and value unsurpassed in the industry.



St

SPECIFICATIONS

LONGEVITY	GAUGE	TENSILE:	PURITY:	WARRANTY:
75 years	24	250	97+%	15 years

Coated Steel

A RainElements Coated Steel Roof Drainage System combines the amazing strength of steel with your own customized colour choice. Our coated roof drainage systems are first galvanized and then electrostatically powder coated, providing extreme durability. The powder coating process is specifically designed for outdoors and has outstanding UV resistance with a beautifully smooth finish.



Cs

SPECIFICATIONS

LONGEVITY	GAUGE	TENSILE:	PURITY:	WARRANTY:
75 years	24	250	97+%	15 years

- ANTHRACITE
- TESTI DE MORO
- JET BLACK
- CUSTOM COLOURS

Fine European technology and craftsmanship with local service and support

RainElements stocks all components in Cloverdale B.C. and we are ready to fill almost any order within days. Our attention is on service and support and we reply to all inquiries and requests for estimates within 24 hours.

Installation videos are available on our website at www.rainelements.ca or on Zambelli's website at www.zambelli.de/en/roof-drainage.html

Our preferred Installers have been chosen based on their excellent reputation and experience in the industry. Together, RainElements, Zambelli and our preferred Installers form a solid team ready to supply and install perhaps the classiest, eye catching aspect of any building.



Re **Cu** Copper **Zn** Zinc
St Steel **Cs** Coated steel

Rain elements

EUROPEAN GUTTER SYSTEMS

IN PARTNERSHIP WITH
zambelli

#204 • 18428 53rd Avenue
Surrey B.C. Canada V3S 7A4
604.808.8955
info@rainelements.ca

rainelements.ca

Contact your certified **Rain elements** dealer below for a free quote.